

Sun Odyssey

479



S U M M A R Y

- > SPECIFICATIONS
- > KEY POINTS
- > EXTERIOR
- > INTERIOR
- > SAILS
- > CONSTRUCTION
- > UPHOLSTERY
- > VINYL HULL WRAP
- > ELECTRONIC PACKAGES



JEANNEAU



PROVISIONAL TECHNICAL INFORMATION

Overall length with bowsprit: 14,43 m / 47'4"
 Overall length: 14,05 m / 46' 1"
 Hull length: 13,65 m / 44' 9"
 Waterline length: 12,54 m / 41' 1"
 Beam: 4,49 m / 14' 8"

Displacement: 10.809 kg / 23.830 lbs
 Standard keel draft: 2,24 m / 7' 4"
 Shoal keel draft: 1,65 m / 5' 4"

Cabins: 3
 Berths: 6 (+2)

Power engine:Yanmar 57 Hp / 42 kW
 Yanmar Sail Drive 80 Hp / 59 kW
 Fuel capacity: 240 l / 63 US gal
 Water capacity: 615 l / 163 US gal
 Fridge capacity:..... 255 l / 67 US gal

Sail area:
 - Standard96 m² / 1 033 Sq ft

CE Category:A10 / B11 / C14 / D16
 Designers: Philippe Briand - Jeanneau Design

VERSIONS • LAYOUTS

Fixed keel version
 Shoal draft version

3 cabins / 2 heads
 3 cabins / 3 heads

Interior woodwork in Teak or Light Oak

Offshore cruiser, elegant and very comfortable.

EXTERIOR

Comfort and performance for passagemaking:

- Powerful, balanced and modern hull designed by Philippe Briand, that combines a long waterline length and a hard chine for speed and comfort at sea.
- Sleek deck lines, safe and ergonomic with flush hatches and integrated running rigging.
- Sail plan with a high aspect ratio. Multiple choices including: self-tacking jib, large, overlapping genoa, Code 0, furling mast, etc...
- Safe and ergonomic cockpit with lines led back to helm stations.

Relaxation and aesthetics:

- Large cockpit with full-function table
- Fold-down transom for easy access to the sea and sundeck
- Sleek deck with curved windows, flush panels and integrated running rigging

INTERIOR

Light, volume and ventilation:

- A multitude of ports and hatches for ventilation and light
- 3 distinct zones in the saloon designed to allow each to be used independently without constricting movement throughout the interior
- Light and luxury down below with solid wood, mat varnish, polished stainless steel, leather and a full selection of interior fabrics.

Lots of features:

- All the features of the larger Sun Odysseys concentrated on the same boat
- Plenty of choices available: Different interior layouts, sail plans, keel and fabrics allow each owner a high level of personalisation
- Choice of woodwork : Teak or Light oak

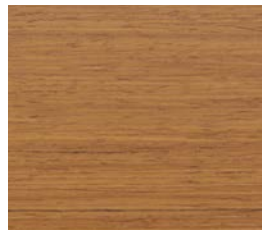

Teak



Light oak

HULL AND KEEL: Modern and balanced

- **Philippe Briand design.**
- **Deep keel** (2,24 m) or shoal (1,65 m).
- **Hard chine on hull** creates stability and enhances interior volume.
- **Long water line** provides performance under sail and power.
- **Moderate freeboard** lends a beautiful and sleek look to the hull along with the 8 hull ports and hard chine.



DECK AND COCKPIT: Liveability, comfort and safety

- **Twin helm steering moved far aft**, keeps the cockpit clear and gives easy access to the transom
- **Harken deck hardware:** winches, blocks, tracks designed to make sail handling easy from the helm
- **Easy access to the sea** thanks to a wide drop-down aft platform (option).
- **Large cockpit table** with storage, lighting, icebox.
- **Flush hatches and integrated running rigging** gives the deck a sleek look and makes movements onboard safer.
- **Lots of storage:** 2 lateral lockers, 2 large lockers under the helm stations, 1 large locker for the optional generator. Forward sail locker and deep anchor locker.



DECK

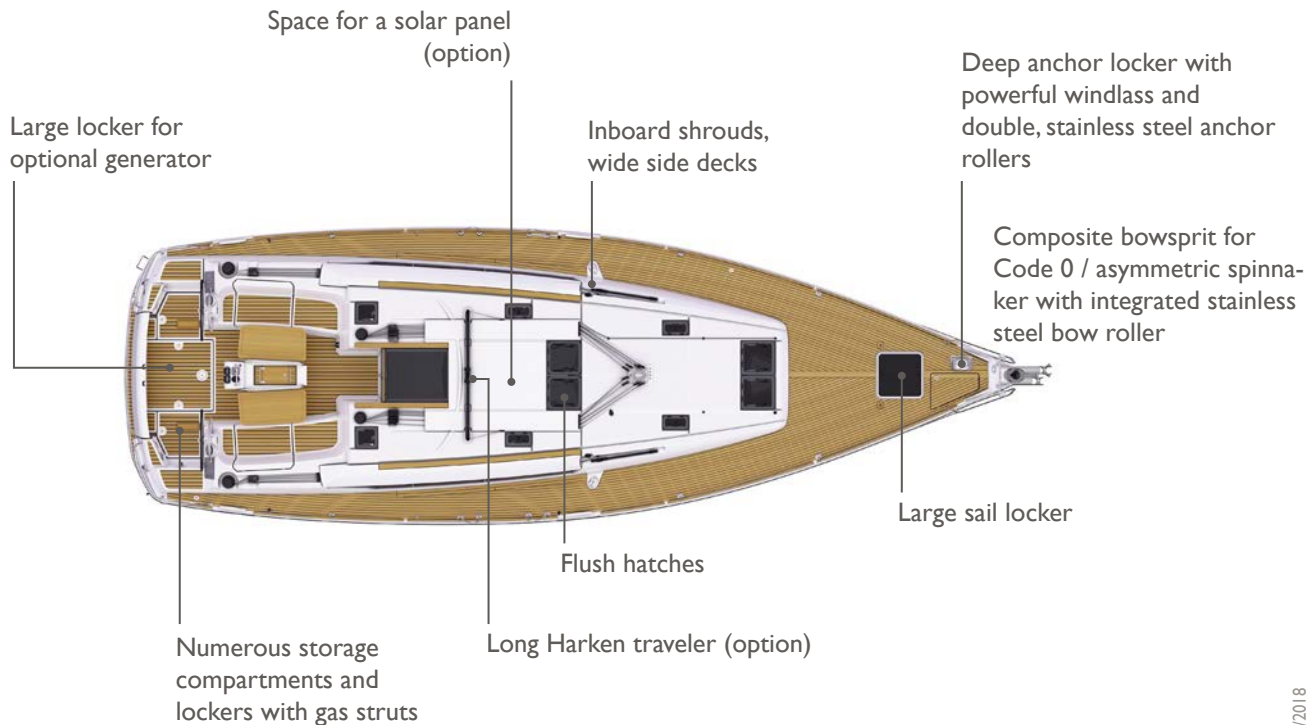

DECK (continued)



Additional opening port in each aft cabin (Trim Level)

Companionway hatch with hinged double doors



Harken deck hardware

Wide drop down platform

Flush hatches and integrated running rigging

All sheets lead aft with optional Harken «Rewind» winches available



Swim platform option

Twin helm stations with optional GPS screens

Large table with storage



Very comfortable helm position without any interference from the backstays

A TRULY MULTIPURPOSE BOWSPRIT

Better look:

- Modern and elegant
- Sculpted fiberglass part flows into hull lines



Better anchoring:

- Stainless steel anchor fitting is positioned further from the bow to ensure more clearance
- Anchor roller is closer to the centerline for easier anchoring and retrieval and less hunting when at anchor
- Fixed, metallic bobstay protects the bow and stays out of the way when anchoring

Better sailing:

- 1 - Reinforced attachment point for Code 0
- 2 - Additional tack point attachment at the end of the bowsprit for larger asymmetric spinnakers



INTERIOR: Space, style and comfort

All the attributes of the larger Sun Odyssey come together on this yacht:

- **Spacious interior** with choice of 2 layouts.
- **An exceptional layout in the saloon**, separate zones for living aboard plenty of functional details.
- **Luxurious materials**, set off by all LED lighting.
- **Numerous and practical storage lockers**, for offshore cruising with friends and family.
- **Light and ventilation:** 8 hull ports, long deckhouse windows, lots of opening ports and flush hatches.
- **Personalisation:** Choice of different fabrics, floorboards and a full list of options allow you to chose the combination that is right for you.



INTERIOR LAYOUTS

3 cabins version / 2 heads



3 cabins version / 3 heads



SALOON

U-shaped saloon holds 8 people without interfering with the other zones aboard. View of the sea and very large table.



Large, fixed hull ports

Several optional upholstery choices available with pillow back rests

Folding deluxe table (optional) with leather-lined central plateau with storage

LED indirect lighting under kickboard (option)



Large storage compartments under the seating, easy access to a storage compartment with gas lifter. Bar cabinet and storage basket



Optional seating allows 8 people to be seated around the table. Chairs are delivered with a tie-down system

GALLEY (3 cabins version / 2 heads)

Large, functional L galley makes cooking easy at sea or at anchor.

Space for optional
microwave

175L Fridge with optional vertical door,
80L freezer



Utensil drawer

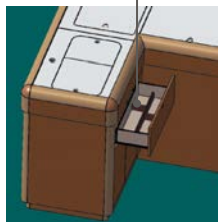

Easy access to upper
cabinets with fiddles

Spice rack

3-burner stove with thermostatically
controlled oven (option)

GALLEY (3 cabins / 3 heads version)

Long galley with multiple, large storage compartments

Multiple, large storage compartments



Fixed bench seat provides additional seating and bracing position for galley (option)



Space for optional microwave

3-burner stove with thermostatically controlled oven

Fridge compartment (175L),
freezer compartment (80L)

CHART TABLE STARBOARD : (3 cabins version, 2 heads)

Relaxation zone with view of the sea and of the TV, central bar cabinet, plush seating with armrests.

Option: ability to view and control the GPS using a smartphone or tablette



Electrical panels 12V behind a drop-down door

2 optional seats with pillow back rests

Book storage behind the backrest



Large, leatherette-covered navigation station that is designed for use with a laptop computer and can convert into a sofa



CHART TABLE PORTSIDE (3 cabins / 3 heads version)

Very large desk with lots of dedicated storage compartments, full integration of the latest entertainment and navigation technologies

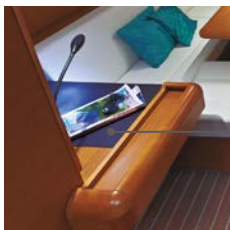

Leatherette-lined desk with space for a laptop computer

Electrical panels placed behind a drop-down door, location of optional electrical panels



Storage niche under the nav table

FORWARD OWNER'S CABIN:

Spacious head compartment with fully separate shower, overhanging berth, lots of storage and desk.

Very large head compartment with fully-separate shower, moulded countertop and sink, plenty of storage



AFT CABINS

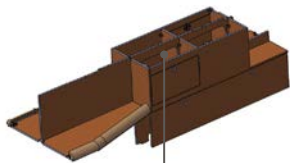

Up to 5 ports and hatches : hull port, one or two* opening cockpit ports deck hatch and side window in each cabin

Storage between the two aft cabins



Indirect lighting

Cabinets along hull sides

Hanging locker

Head compartment with separate shower, moulded countertop and sink, WC and numerous storage compartments



Wet hanging locker

* Optional second cockpit port

SAIL AND RIG PLANS: Sails for every sailor

Select the sail plan that best fits your style :

- **High aspect ratio rig** for maximum performance while limiting the loads on the sheets.
- **Inboard shrouds and genoa tracks** allow better trim of the standard or performance sails and easy circulation on the side decks.
- **Code 0** offered as an option for sailing in light wind conditions.

SPECIFICATIONS

FURLING MAINSAIL :

- Dacron®
- Horizontal panels
- UV-stabilised thread
- Radial reinforcements
- Draft stripe
- Adjustable leech line
- UV protection on clew
- Replaces the standard mainsail
- Included in furling mast option

• **Area : 38 m²**



SHORT OVERLAPPING FURLING GENOA (106%) :

- Dacron®
- Horizontal panels
- UV-stabilised thread
- Webbing strap at head
- Bolt-rope for furler
- Anti-UV protection on foot and leech
- Draft stripe
- Webbing strap at tack
- Reefing marks
- Adjustable leech line

• **Area : 46,5 m²**



ADVANTAGES

- High-aspect rig for maximum performance
- Easy to handle sail plan
- Versatile and balanced sail plan at all sailing angles

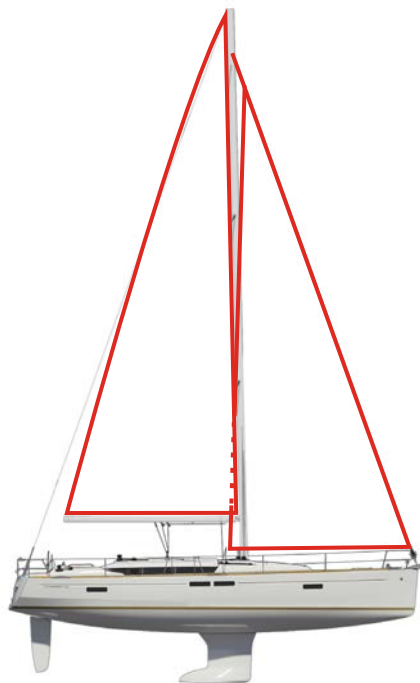

I = 17,20 m / 56'4"
J = 5,66 m / 18'6"
P = 16,62 m / 54'5"
E = 5,10 m / 16'8"

MAINSAILS

CLASSIC MAINSAIL : 49,6 m²

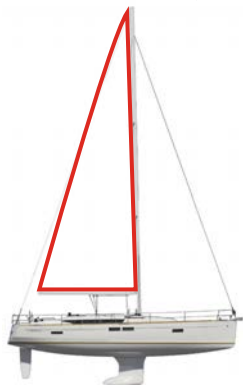

FORESAILS

SELF-TACKING JIB : 38,4 m²



CODE 0 : 84,4 m²

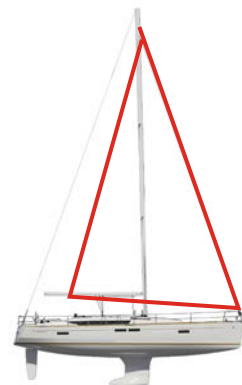

SPECIFICATIONS

BATTENED MAINSAIL :

- Dacron®
- Horizontal panels
- Stainless steel eyes
- UV-stabilised thread
- Draft stripe
- Radial reinforcements
- Adjustable leech line
- Loose-footed
- Full batten
- 2 reef points each with singleline reefing system. (Third classic reef point)



- **Area : 49,6 m²**

SPECIFICATIONS

SELF-TACKING FURLING JIB :

- Mylar/taffeta X-Grid fabric in grey colour
- Triradial cut
- UV-stabilised thread
- Webbing strap at head
- Bolt-rope for furler
- Anti-UV protection on foot and leech
- Draft stripe
- Radial reinforcements
- Webbing strap at tack
- Adjustable sheet attachment
- Adjustable leech line
- Replaces the standard genoa
- Requires deck hardware for self-tacking jib

• **Area : 38,4 m²**



ADVANTAGES

- Hands-free tacking
- Great up-wind performance
- Perfect for short-handed sailing

PERFORMANCE SAILS : MYLAR TAFFETA X-GRID

Working in collaboration with Dimension-Polyant and Technique Voiles, Jeanneau has developed a new Mylar Taffeta X-Grid fabric for the Performance range.

The triradial construction of the sail contributes to superior shape holding, but other forces can act on the individual panels. By using a specially-designed X-Grid[®] of fibres angled at 6° laminated into the fabric, better bias control can be achieved which makes the sail more resistant to deformation and aging.

The performance of these new fabrics provides a more stable sail cloth that is lighter, easier to handle, with better shape control over time.

These new Performance sails are easily recognisable; they include a taffeta laminate that is light grey that gives them a very “hi-tech” look.

- 1 - Protective taffeta
- 2 - Polyester film
- 3 - X-Grid[®] fibres
- 4 - Polyester scrim

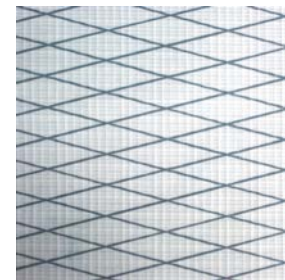

SPECIFICATIONS

CODE 0

Selden continuous line furler :

- Laminate Mylar/Aramid X-Grid fabric in light grey
- Triradial cut
- Anti twist luff cord
- UV-stabilised thread
- Straps for sheet attachment
- Adjustable leech and foot lines
- Requires rigging for asymmetrical spinnaker / Code 0
- **Area : 84,4 m²**



ADVANTAGES

- A light wind sail designed for use between 60° and 120°
- Continue to sail when others have given up and turned on the motor
- Continuous line furler allows easy deployment and furling from the cockpit
- Ideal addition to boats with small overlapping jibs and self-tacking jibs



CODE 0: MYLAR ARAMID X-GRID

For the development of the new Code 0 sails on a continuous line furler, Jeanneau selected a sail cloth that is perfectly adapted for use in light airs. Highly resistant, light weight and able to be furled, the Mylar Aramid X-Grid has a light grey finish that is translucent.

Unidirectional Aramid fibres, vacuum-bagged together between two polyester films, provide an unequalled resistance to weight ratio. This ultra light sail is easy to handle and fills with the slightest puff of wind. Adding the X-Grid® polyester fibres at a 6° angle provides excellent bias control in all directions and improves sail shaping, as well as, resistance to tearing.

Lastly, a taffeta is added to the external laminate of the sail cloth to protect the sail from ultraviolet light and wear during furling or storage.

The Code 0 sails from Jeanneau integrate these high-performance materials to meet the exacting demands of our owners. In addition to these high-end materials, the look of these sails sets Jeanneau apart.

- 1 - Polyester film
- 2 - X-Grid® fibres
- 3 - Unidirectional Aramid fibres
- 4 - Protective taffeta

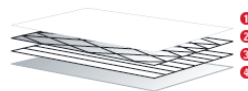

SO479 - 07/2018

PRISMA PROCESS



Leader in vacuum bagging technology for the construction of racing boats, JTA developed an resin injection process applicable to the construction of cruising boats. By using advanced engineering, precisely positioned layers of glass fabric and mat and specially developed core materials, Jeanneau is able to mould a deck to exacting tolerances.

Jeanneau's leadership in this domain gives it a substantial advantage over its competitors and ensures unequalled quality to the customer.

This 21st century technology allows Jeanneau to manufacture complex fibreglass parts with:

- Perfect finish on both sides (no need for a counter mould)
- Reduced weight (providing the sailboat better stability/performance)
- Increased strength and rigidity of the piece (quality of lay-up)
- Reduction by 90% of VOC emissions (environmentally-friendly)
- Optimum working conditions for the production team (no contact with resins/catalysts)
- High quality parts (precise control of gelcoat, core materials and resin injection)

The deck of the Jeanneau 54 is the largest mass-produced injection fibreglass part in the world.

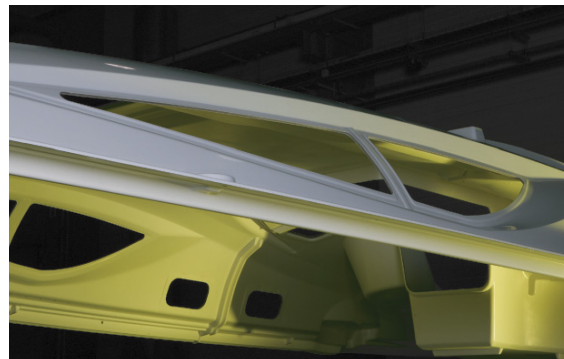

COUNTER-MOULDING

3rd generation hull structure

Jeanneau has long been known for strong and seaworthy boats. Today the technology of boatbuilding has evolved, but our commitment to this tradition has not wavered. The Jeanneau 3rd Generation Hull Structure combines the latest in fiberglass technology with modern yacht design to deliver a structural reinforcement perfectly adapted to the demands of the offshore sailor.

- ❶ High-load zones cut-out for access to the hull
- ❷ Integrated repair area at aft end of keel
- ❸ Structure is precisely placed in the hull
- ❹ Glued and relaminated to the hull for strength
- ❺ Acts as a support for the floorboards
- ❻ Keel bolts located near vertical members and through counter mould and hull
- ❼ Limber holes at hull level for efficient drainage
- ❽ Counter mould remains below level of floorboards and is not visible

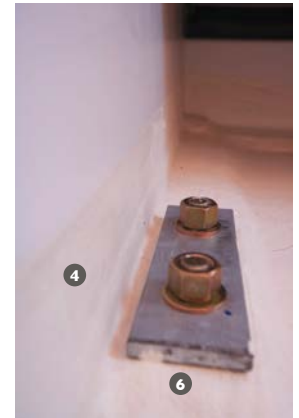

ALPI WOOD

SALES POINTS:

Environmental:

- Ayous (Triplochiton scleroxylon - Sterculiacées) trees in managed forests of indigenous hardwoods are selected and cut, with a constant care given towards long term preservation of natural resources.
- Teak and other soft rainforest woods often come from geopolitically sensitive regions and are not managed in a sustainable way.

Quality:

- These ALPI wood panels are substantially more expensive and reliable than standard marine plywood. They are used by top of the line furniture manufacturers, as well as many exclusive super-yacht builders (for example Azimut and Ferretti only use ALPI wood).
- Consistency of finish and colors throughout the boat.
- Elimination of “defects” in wood panels.

Durability:

- Harder finish that is more resistant to humidity
- Better resistance to UV
- Easier repairs as veneer is tinted through and through so clear varnishes can be used



SALOON



UPHOLSTERY leather / leatherette

▶ *Chocolat*



BACKRESTS & SEATS

▶ *Pure White*

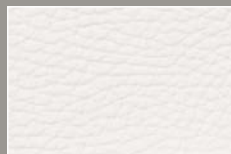

Infill cushion for convertible berth in Linen

INTERIOR WOOD

▶ *Standard:*
Teak

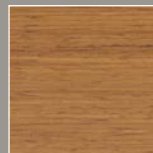

▶ *Option:*
Light Oak

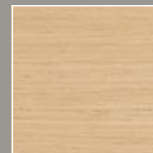

FLOOR

▶ *Standard:*
Light Oak laminate



▶ *Option:*
Dark Oak laminate



CABINS

SEAT

▶ *PVC Pure White*

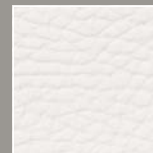

BEDS

▶ *Premium mattress*

Removable mattress cover fabric with Ultra-Fresh® is anti-microbial, anti-bacterial and non-allergenic

SALOON



UPHOLSTERY leather / leatherette

▶ *Chocolat*



BACKRESTS & SEATS

▶ *Linen*



Infill cushion for convertible berth in Linen

INTERIOR WOOD

▶ *Standard:*
Teak

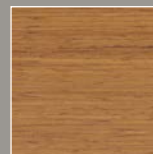

▶ *Option:*
Light Oak

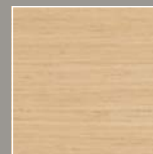

FLOOR

▶ *Standard:*
Light Oak laminate



▶ *Option:*
Dark Oak laminate



CABINS

SEAT

▶ *PVC Pure White*

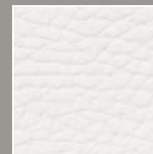

BEDS

▶ *Premium mattress*

Removable mattress cover fabric with Ultra-Fresh® is anti-microbial, anti-bacterial and non-allergenic

SALOON



UPHOLSTERY leather / leatherette

▶ *Chocolat*



BACKRESTS & SEATS

▶ *Chestnut*



Infill cushion for convertible berth in Linen

INTERIOR WOOD

▶ **Standard:**
Teak

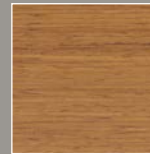

▶ **Option:**
Light Oak

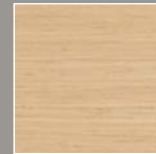

FLOOR

▶ **Standard:**
Light Oak laminate



▶ **Option:**
Dark Oak laminate



CABINS

SEAT

▶ *PVC Pure White*

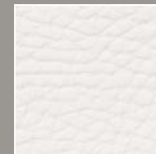

BEDS

▶ *Premium mattress*

Removable mattress cover fabric with Ultra-Fresh® is anti-microbial, anti-bacterial and non-allergenic

SALOON



UPHOLSTERY leather / leatherette

▶ *Chocolat*



BACKRESTS & SEATS

▶ *Marine*

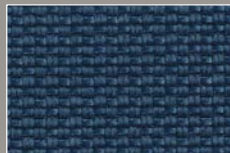

Infill cushion for convertible berth in Linen

INTERIOR WOOD

▶ *Standard:*
Teak

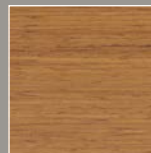

▶ *Option:*
Light Oak

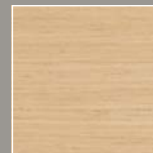

FLOOR

▶ *Standard:*
Light Oak laminate



▶ *Option:*
Dark Oak laminate



CABINS

SEAT

▶ *PVC Pure White*



BEDS

▶ *Premium mattress*

Removable mattress cover fabric with Ultra-Fresh® is anti-microbial, anti-bacterial and non-allergenic

SALOON



UPHOLSTERY leather / leatherette

▶ *Chocolat*



BACKRESTS & SEATS

▶ *Silver*



Infill cushion for convertible berth in Linen

INTERIOR WOOD

▶ *Standard:*
Teak

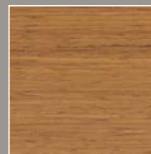

▶ *Option:*
Light Oak

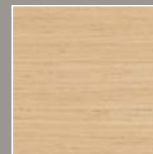

FLOOR

▶ *Standard:*
Light Oak laminate



▶ *Option:*
Dark Oak laminate



CABINS

SEAT

▶ *PVC Pure White*

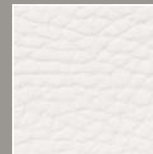

BEDS

▶ *Premium mattress*

Removable mattress cover fabric with Ultra-Fresh® is anti-microbial, anti-bacterial and non-allergenic

SALOON



Infill cushion for convertible berth in Linen

INTERIOR WOOD

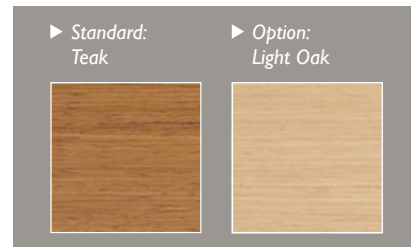

FLOOR

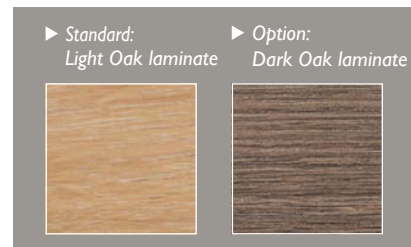

CABINS

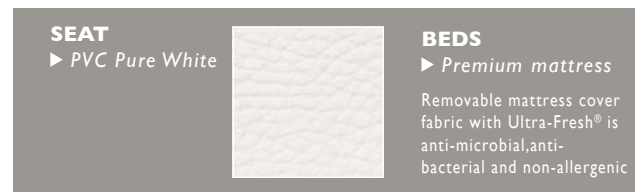

EXTERIOR UPHOLSTERY

SPRAYHOOD PROTECTION BIMINI / LAZY BAG



▶ Sunbrella® Plus Taupe



COCKPIT CUSHIONS



▶ Sunbrella® Sling Taupe



> VINYL HULL WRAP

**Jeanneau proposes 10 choices of hull colours and finishes.
Customize your boat!**

HULL WRAPPING

▶ Gloss metallic black

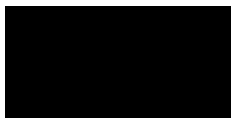

▶ Brushed titanium



▶ Gloss metallic dark bleu



▶ Matte metallic frosty blue



▶ Pearl dark green

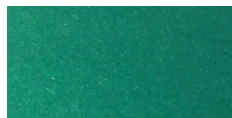

▶ Matte metallic blaze orange



▶ Gloss metallic brown



▶ Gloss burgundy



▶ Gelcoat white



▶ Champagne



AVANTAGES OF VINYL HULL WRAPPING

- Customized
- Unique
- Less expensive than paint
- Repairable
- Many colours and finishes
- Removable
- Easy for the resale

To complete this offer, 4 choices of hull stripping are available when ordering a hull wrap.

HULL STRIPING

▶ 801 Black



▶ 893 Charcoal Metallic

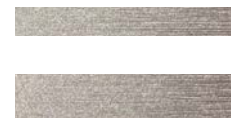

▶ Gloss metallic dark bleu

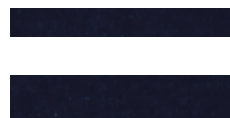

▶ White

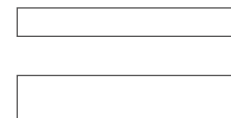

▶ Champagne



LITHIUM BATTERIES

EPSILON – TECHNOLOGIE LIFEPO4



GREAT AUTONOMY
100% of useable energy



LIGHTWEIGHT!
With equivalent energy:
More than 65% in weight gain
= reduced volume !



MAXIMUM SERVICE LIFE
≈ 5 000 cycles



TOLERANCE TO HIGH TEMPERATURES



OPTIMUM COMFORT
Compatible with powerful
230V AC/DC inverters!
NO NEED TO COMPROMISE!



SUPER-FAST CHARGING
2 hours when under power
1 hour when charging with solar cells
in optimal conditions



PEACE OF MIND
Very low self-discharge;
store your battery safely
for several months

Number of domestic batteries 90Ah Lithium	
Sun Fast 3200	2
Sun Fast 3600	2

Sun Odyssey 349	1
Sun Odyssey 389	1
Sun Odyssey 410	2
Sun Odyssey 419	2
Sun Odyssey 440	2
Sun Odyssey 490	3

Sun Odyssey 449	2
Sun Odyssey 479	3
Sun Odyssey 519	3

Jeanneau 51	3
Jeanneau 54	3

Sun Odyssey 479-519 Cruising Electronic Pack

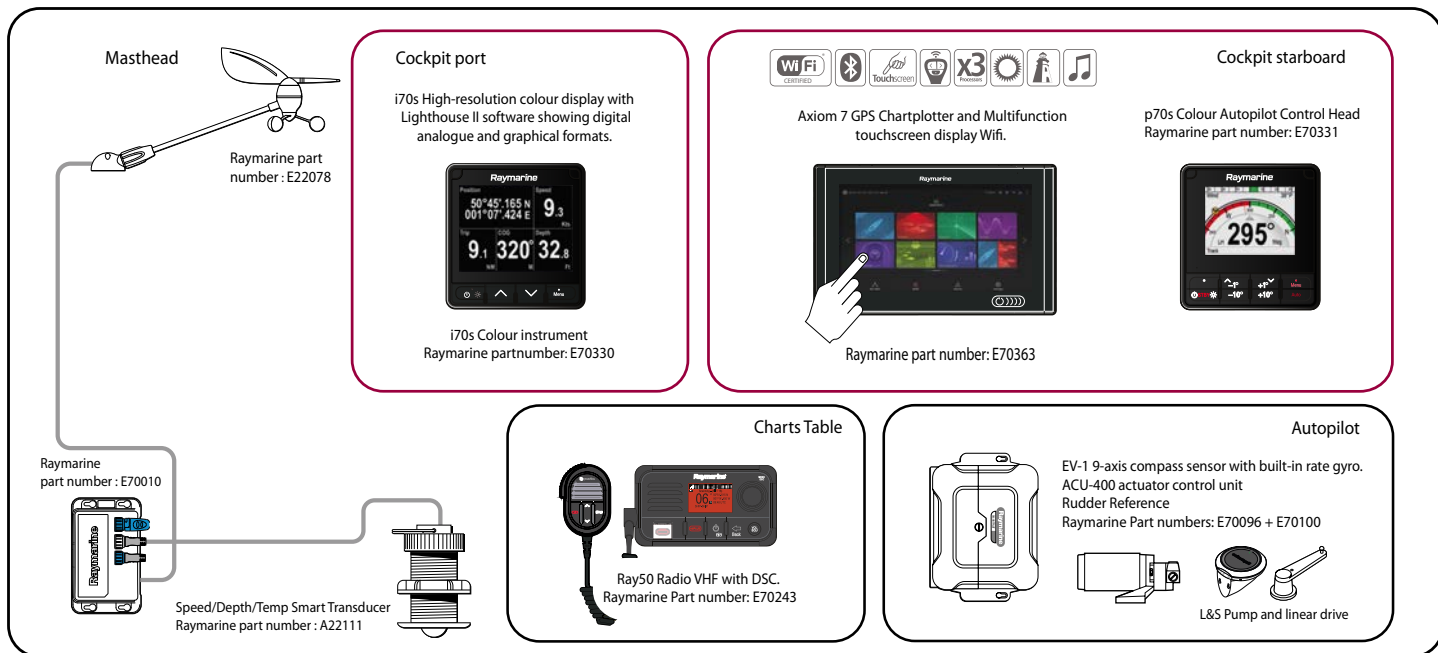

Sun Odyssey 479-519 Offshore Electronic Pack

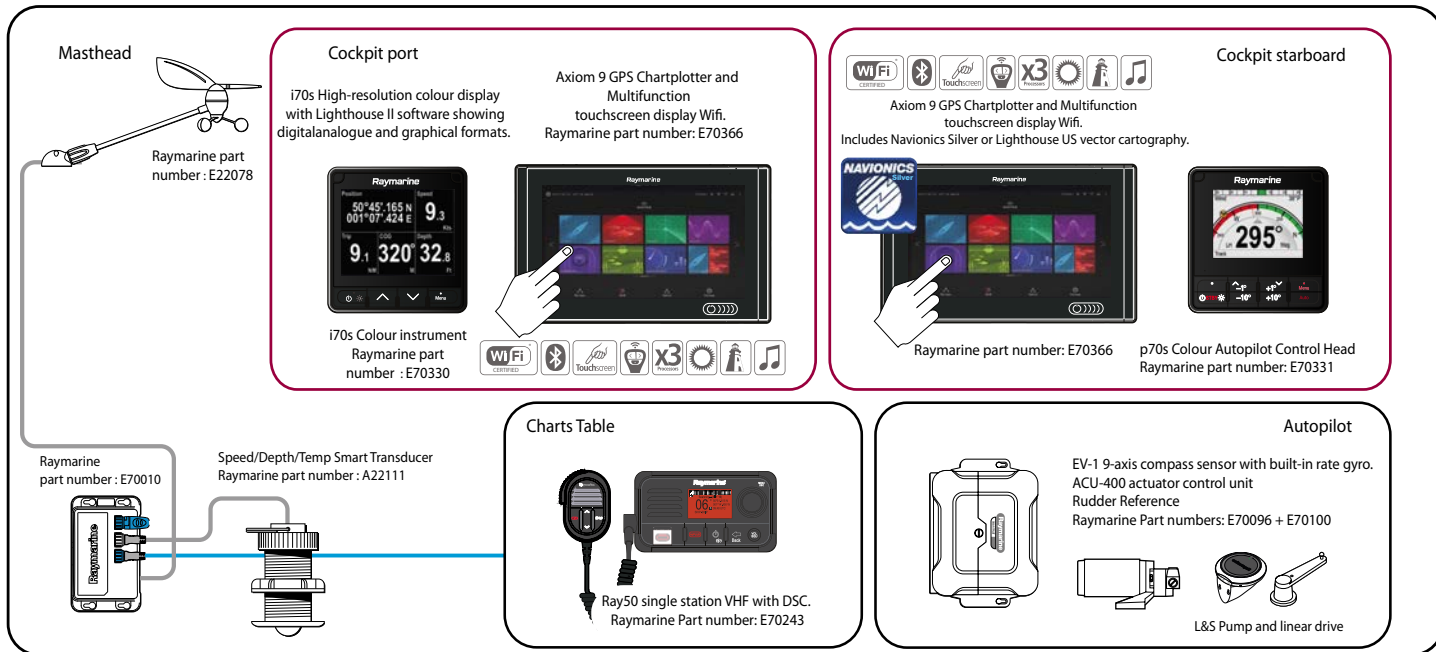

Sun Odyssey 479-519 Ocean Electronic Pack

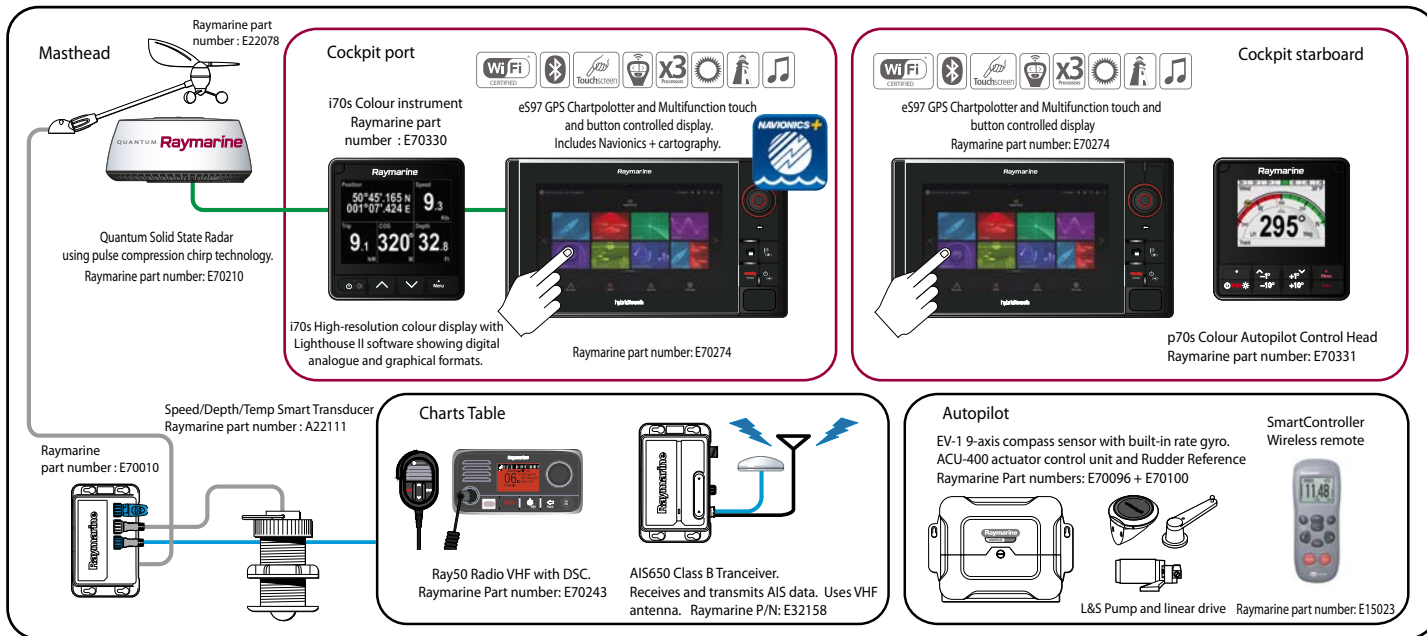



July 2018 - Non contractual document