

# QUICKSILVER® CAPTUR

## 905 Pilothouse



### SPECIFICATIONS

• Length Overall (M)	8.88
• Length of hull (M)	8.5
• Beam Maximum (M)	2.99
• Height - Without Canvas (M)	3.32
• Dry Weight (Kg)	3100
• Fuel Capacity (L)	400/580 optional

• Water Capacity	100
• CE Design Category	B
• Maximum Number of People	10
• Maximum Power (HP / KW)	500 / 368
• OB Shaft Length	1-XXL/2-XL
• Max. Load (People, Gear, Engine) (kg)	1445

### STANDARD EQUIPEMENT

- Bow Roller
- Swim Platform & ladder
- Starboard and Port Windshield Wiper
- Windshield Wash
- Dual Battery System
- OB Pre-Rigging
- Dinette Seat Configuration
- Anchor Locker

- Hull Side Windows
- Fish lockers
- Cockpit Rod Storage
- Rodholders
- Cockpit Shower
- Self Bailing Cockpit
- Cockpit Flood light
- Fishing Station
- Navigation lights
- Electric Bilge Pump

- 6 Berths with Filler/Cushions
- Hull Portlights
- Cabin lights
- Opening Side Window
- Starboard Pilothouse Entry Door
- Table/Dinette
- Bait preparation station
- Transom Door

- Smartcraft Speedometer/Tachometer
- Hydraulic steering
- 12v electrical socket
- Separate Head Sea toilet, Sink & Pull Out Shower
- Galley with sink & tap
- Pilot & Co-pilot Seat
- Fire Extinguisher
- Foredeck/Head Portlights

#### SMART Edition

- Cabin Comfort Pack
- Cockpit Comfort Pack
- Fish Pack

#### Fish Pack

- Interior Rod Racks
- Rodholders on Pilothouse
- Fishing station upgrade (Extra rod holders 2 on fish station, 2 on coaming caps, Raw water washdown, Livewell system)

#### Cockpit Comfort Pack

- Port flip seat
- Starboard flip seat
- Bow cushion
- Twin individual flip seats in fish station
- Cockpit table

#### Cabin Comfort Pack

- Refrigerator
- Single Burner Stove
- Microwave
- Interior curtains

#### Exterior Lightning Pack

- Spotlight
- LED Courtesy lights

#### Electronic Pack

- 9" GPS/Chart plotter
- Stereo Fusion with 6 speakers

#### Electronic Pack Dual Station

- 9" GPS/Chart plotter
- 2nd Helm 7" GPS/Chart plotter NSS evo 2
- Stereo Fusion with 6 speakers

### PACKS & OPTIONAL EQUIPMENT

#### Optional Equipment

- Hull Color
- Swim platform extension
- Anti-Theft Security Eye
- Second Helm Station
- Vesselview
- Roof Hatch
- Sun Awning
- Complete Enclosed
- Canvas
- Exterior Helm Cover
- Shore Power
- VHF Simrad RS12
- Diesel heat
- Bow Thruster
- Bow Electrical Windlass
- Transom Electrical Windlass

- Electric Trim Tabs
- Grey water system
- Single Airconditioner with Shorepower
- Single Airconditioner with Shorepower & Gas or diesel generator
- Dual Airconditioner with Shorepower & Gas or diesel generator
- Water heater
- Radar Simrad 3G
- Joystick Piloting with Skyhook Digital Anchor
- 580L Fuel tank

### MERCURY ENGINE OFFERING

#### Single Configurations

- 225 XXL Verado
- 250 XXL Verado
- 300 XXL Verado
- 350 XXL Verado
- 400 XXL Verado

#### Twin Configurations

- 175 XL Verado
- 200 XL Verado
- 225 XL Verado
- 250 XL Verado

For more information, please to visit our Quicksilver website [www.quicksilver-boats.com](http://www.quicksilver-boats.com)

As a company committed to continuous product improvement specifications are subject to change.

Modified by VZA 26/08/2016 - Product sheet MY2017: 1 Sept 2016 - 30 Aug 2017

# QUICKSILVER® CAPTUR

## 905 Pilothouse

The days you had to choose between comfort and performance, between fishing and cruising are gone. With the 905 Pilothouse you can have both. Designed without compromise for fishing, adventure & fun, and all in perfect safety and comfort. The 905 Pilothouse is suited for offshore cruising (category B) and carries up to 10 people.

### SAFETY

- Suitable to navigate both offshore and inshore (category B)
- Safety is ensured by the high freeboards and convenient positioned grab rails
- The high-spec electronic pack, which includes a GPS for precise navigation, and a VHF for secure communication
- Single or twin Mercury engine configuration with up to 500 hp ensure safe and agile handling in a variety of weather and sea conditions
- Safe on-board circulation with both port and starboard bow to stern access and safe side to side passage in the transom area on the transom bridge

### FEATURES & BENEFITS

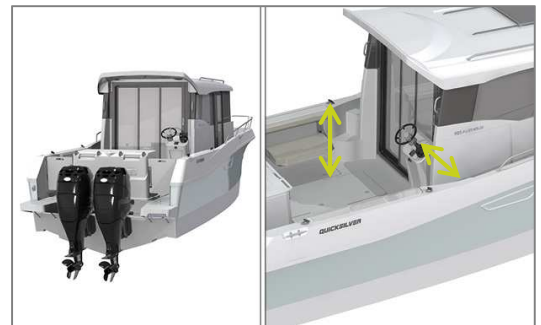

### UNCOMPROMISED FISHING

- Comprehensive fish station featuring a sink, cutting board, cold water wash, twin individual flip seats and rod holders
- Fish Pack upgrade adds a livewell, raw water wash-down, extra rod holders and in-cabin safe rod storage and additional stainless steel rod holders
- Fish station slides back at the touch of the button to maximize cockpit area and integrated fish lockers in the cockpit floor offer a good solution for packing away the catch
- The optional second helm allows for precision navigation and control while fishing



### EXCELLENT CRUISING COMFORT

- Ample seating possibility in cockpit and bow area
- Fully featured galley includes a sink, LPG stove and optional micro-wave, fridge
- Accommodation for 6 with a full size forward berth for 2, a full size mid-berth for 2 and a convertible solution for single or dual accommodation in the main cabin.
- Opening port lights and skylight throughout for ventilation and natural daylight
- Heating and/or air conditioning system for a maximum of comfort all year long
- Separate head with enclosed toilet and pull-out shower
- Exterior lighting in cockpit for night-time operation



For more information, please visit our Quicksilver website [www.quicksilver-boats.com](http://www.quicksilver-boats.com)

As a company committed to continuous product improvement specifications are subject to change.

Modified by VZA 26/08/2016 - Product sheet MY2017: 1 Sept 2016 - 30 Aug 2017