

Sun Odyssey 33i

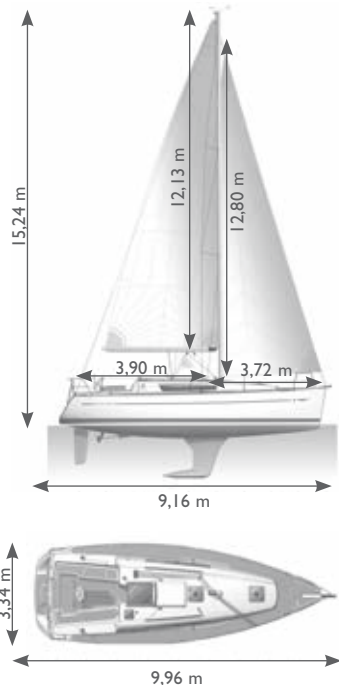

Sun Odyssey 33i Performance

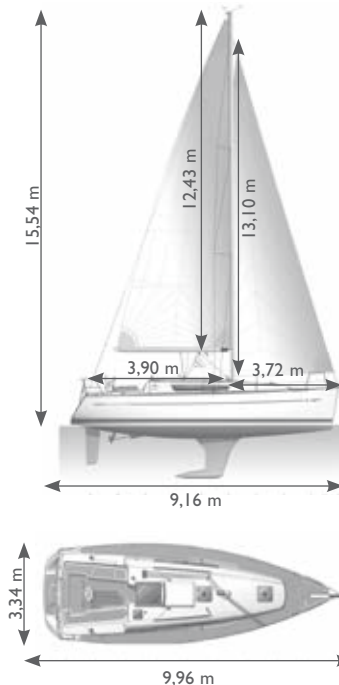

Certification conform with CE regulation.

	SO 33i	SO 33i Performance
SPECIFICATIONS		
Overall length	9,96 m	9,96 m
Hull length	9,74 m	9,74 m
Waterline length	9,16 m	9,16 m
Beam	3,34 m	3,34 m
Displacement light load with deep draft keel	4895 kg	4895 kg
Standard draft cast iron fin keel with elongated bulb and exterior epoxy barrier coat	1,90 m	1,90 m
Standard keel weight	1500 kg	1500 kg
Shoal draft cast iron fin keel with elongated bulb and exterior epoxy barrier coat	1,47 m	-
Shoal keel weight	1695 kg	-
Swing keel version galvanised centreboard located in an external iron keel fin	0,85-2,20 m	-
Swing keel weight	1516 kg	-
Air Clearance measured from waterline to top of the mast	15,16 m	15,46 m
CE category (*swing keel version B6)	A6 / B8*	A6 / B8
Architect/designer	M. Lombard	M. Lombard
Water capacity	160 L	160 L
Fuel rotomolded tank located under aft berth with deck fill	140 L	140 L
Holding tank rotomolded tank located in head compartment with valve for overboard discharge via gravity and deck fitting for pump out	85 L	85 L
Fridge compartment with vertical access	100 L	100 L
SAILS		
Classic mainsail 80% battened, polyester sailcloth, Rutgerson® stainless steel eyes and 2 reinforced reef points with auto reef	■ 26,5 m ²	-
Furling genoa 115% high-tenacity Dacron cloth, UV luff protection, Rutgerson® stainless steel eyes	■ 25 m ²	-
Performance mainsail , semi-full batten, Prestige series tri-radial with sandwich construction of double taffeta layers and Mylar for form stability, 2 automatic reefs	-	■ 27,6 m ²
Performance furling genoa tri-radial Prestige series with sandwich constructions of double taffeta layers and Mylar for form stability and UV luff protection, Rutgerson® stainless steel eyes	-	■ 27,7 m ²
Self-tacking jib horizontally-cut in high-quality dacron, UV luff protection, Rutgerson® stainless steel eyes	□ 17,9 m ²	-
Furling mainsail polyester sailcloth, UV luff protection, Rutgerson® stainless steel eyes	□ 25,7 m ²	-
Spinnaker optimal size for boat (not available from Jeanneau)	100 m ²	100 m ²
Total sail area for standard mast and sails	51,5 m ²	55,3 m ²

■ Standard □ Option - Not available

	SO 33i	SO 33i Performance
SAIL HANDLING		
Lazy bag in Sunbrella® Taupe fabric with integrated lazy jacks	■	■
Genoa winches 2 x Harken 35.2 self-tailing winches	■	-
Coachroof winch 1 x Harken 20.1 self-tailing winch	■	-
Coachroof winch 1 x Harken 35.2 self-tailing winch	-	■
Genoa winches 2 x Harken 40.2 self-tailing winches	-	■
Genoa tracks adjustable lead cars	■	-
Turning blocks for genoa sheets	■	■
Harken genoa tracks ball-bearing cars with control lines lead aft to cockpit	-	■
Winch handle 1 x Harken handle with ball-bearing grip	■	■
Line jammers Spinlock, on coachroof	■	■
Mainsheet attached to padeyes forward of companionway hatch with sheet lead back to cockpit winch	■	-
Mainsheet traveller cockpit-mounted Harken traveller with ball-bearing cars and fine tune	-	■
Spinnaker deck hardware 2 x jammers on coachroof, 3-sheave return block on deck, padeyes on side decks	PREMIERE	PREMIERE
Asymmetrical spinnaker gear halyard, 2 sheets, tack line lead forward on deck, 3 blocks	□	□
MAST AND RIGGING		
Selden classic mast aluminium with double spreaders, deck-stepped	■	-
Selden performance classic mast aluminium with double spreaders, 9/10th fractional	-	■
Standing rigging discontinuous 1x19 stainless steel wire	■	■
Backstay fixed	■	-
Backstay adjustable via a block and tackle system 1:16	-	■
Genoa furler with attachment to stemhead fitting and furling line lead aft to roof winch	■	-
Genoa furler racing series with removable drum, double sail slot, furling line lead aft to roof winch	-	■
Running rigging topping lift, mainsail halyard, genoa halyard, mainsheet, genoa sheets	■	-
Dyneema® Running rigging mainsail halyard, genoa halyard, mainsheet with fine tune, genoa sheets, polyester boom topping lift	-	■
Boom vang block and tackle system	■	-
Rigid boom vang with gas cylinder and control line lead aft to the cockpit	-	■
Anchor light and tricolour at masthead, steaming light and bicolour running light on leading edge of the mast	■	■
COCKPIT & DECK STORAGE		
Wood inlay on cockpit bench seating	■	■
Wood cockpit floor inlay	□	□
Cockpit locker 1 large cockpit locker to starboard under bench seat and separate gas locker on stern	■	■
Liferaft locker located in dedicated compartment in stern	35x56x92 cm	35x56x92 cm
Cockpit table large folding table mounted on stainless steel base	PREMIERE	-
Cockpit table folding table mounted on pedestal	-	PREMIERE
Wheel leather-covered steering wheel mounted on steering pedestal with grabrail and pod for instrumentation	■	■
Folding steering wheel	□	□
Compass	■	■
Transom seat folding seat for easy access to the transom	■	■
Engine controls throttle and engine control panel, warning lights, ignition protected by a plexiglass panel	■	■
Swim ladder stainless steel folding ladder mounted on transom step	■	■
Cockpit shower retractable hot and cold water shower with tap	PREFERENCE	PREFERENCE
Cockpit sprayhood wide Sunbrella® Taupe with vinyl windscreen	□	□
Anchor locker forward, room for anchor and tackle	■	■
DECK HARDWARE		
Bow pulpit stainless steel	■	■
Stern pulpits stainless steel with buoy bracket	■	■
Outboard engine bracket mounted on stern pulpit	□	□
Windlass 1000 W combination rope and chain 10 mm, vertical-mounted in the anchor locker, hand-held remote, manual handle	□	□
Anchor roller single roller	■	■
Anchoring kit Delta anchor 16 kg with 28 meters of 10 mm chain and 40 meters of 18 mm line	□	□
Lifelines double level of stainless steel lifelines, stainless steel stanchions	■	■
Toerail	■	■
Cleats 4 x aluminium mooring cleats forward and aft	■	■
Midship cleats	PREMIERE	PREMIERE
Mooring kit fenders and docklines	□	□
Handrails sculpted, long wood handrails on coachroof for secure movement forward	■	■

■ Standard □ Option - Not available

TECHNICAL FEATURES AND OPTIONS		
CONSTRUCTION		
Deck Prisma Process® injected deck, ISO gelcoat surface, discontinuous balsa block coring	■	■
Hull solid, hand-laid fibreglass, ISO gelcoat surface, protective barrier coat	■	■
Structure inner fibreglass grid, high-load zones cut out, drainage system through structure	■	■
LIGHTS		
Flush mounted chromed brass LED ceiling lights in saloon and cabins	■	■
Reading lights in cabins	■	■
Gooseneck chart light mounted at nav station	■	■
ELECTRICAL		
12v alternator output	80 A	80 A
Battery 80 Ah for domestic bank with charge distributor/isolator	■	■
Extra 80 Ah for domestic battery	PREMIERE	PREMIERE
Engine start/domestic battery capacity	80 Ah	80 Ah
Battery switches for engine bank, positive battery switch for domestic bank (when option is fitted) and negative general cut-off switch	■	■
220 v shore power inlet with differential breaker, one 220 v plug per cabin, galley and saloon + 25 A Cristec charger	PREMIERE	PREMIERE
PLUMBING		
Pressurised water distributed through-out the boat via semi-rigid hose	■	■
“Heavy-duty” water pump and accumulator tank for consistent water pressure	■	■
25 litres hot water tank that is connected to engine heat exchanger and 220v system (when 220 v shorepower system fitted)	■	■
Manual bilge pump in the cockpit	■	■
Chromed shower faucets in washroom	■	■
Shower sumps equipped with individual electric pumps with filters and on-off switches	■	■
Manual pump marine toilets	■	■
ENGINE		
Yanmar 3YM20 21 HP , 15.3 Kw with heat exchanger	■	■
Fully soundproofed engine compartment with engine access behind stairwell and from aft cabin	■	■
Stainless steel propeller shaft 25 mm diameter and maintenance free stuffing box	■	■
Fuel/water separator	■	■
Built-in muffler, air ventilation and stainless steel exhaust fitting aft	■	■
Fixed 3-blade bronze propeller	■	-
Folding 3-blade propeller	□	■
COMFORT FEATURES AND OPTIONS		
Fixed windows along coachroof with integrated opening ports	■	■
Pleated curtain kit with integrated insect screens for hatches	PREFERENCE	PREFERENCE
Opening cockpit and roof ports	2	2
Opening cockpit port into aft cabin	2 x PREMIERE	2 x PREMIERE
Opening deck hatch in saloon	■	■
Opening deck hatch in forward cabin	■	■
Opening deck hatch in aft cabin	■	■
Audio docking station Sonichub Simrad and 2 speakers in saloon	PREFERENCE	PREFERENCE
Cockpit speakers watertight	PREFERENCE	PREFERENCE
Forced air heating unit 3900 BTU Webasto® diesel heater installed in cockpit lazarette, vents in forward cabin, aft cabin and saloon	□	□

■ Standard □ Option - Not available

INTERIOR FEATURES AND OPTIONS

WOOD

Fine Teak® laminated panels with solid wood trim around galley, companionway and cabinetry, finished in satin UV stabilised varnish

Laminate floorboards laminated floorboards with light-coloured lines and sealed edges

FORWARD CABIN

Forward cabin with V-berth

Double berth with high-density foam mattress

2 x 1,80 m

Storage locker under berth

Cabinet with hanging rod

Storage cabinet with shelves

Wide, bi-fold door for easy access

Vinyl lining on hull with lateral wood shelf

Reading light

AFT CABIN

Aft cabin

Double berth with high-density foam mattress

2,10 x 2 m

Deep cabinet with shelves and hanging rod

Vinyl lining on hull with lateral wood shelf

Leather storage organiser

PREFERENCE

Reading light

HEAD

Head compartment accessible from saloon with sink, storage cabinet, clothes hook, towel holder, toilet paper holder, shower sump with electric drainage pump

Wet locker

NAVIGATION STATION

Navigation station

Full-featured electrical panel with spare breakers, voltmeter and 12v plug

Aft-facing nav station, seating on bench seat

Navigation desk with storage

SALOON

Saloon with seating, cushions and storage under seating area

Folding saloon table with fiddles

Bottle storage compartment in table with leather cover

Cushion to fit under nav desk to convert portside settee to single berth

PREFERENCE

Upper storage cabinets

Companionway with 4 varnished wood steps

GALLEY

Galley with laminated countertops, chrome plumbing fittings, storage cabinets

L-galley to starboard with round stainless steel sink 100 L, icebox and cutlery storage

Leather storage organiser

PREFERENCE

12v compressor under stove with evaporator plate located in fridge compartment

2-burner stove (this stove is used when microwave option is ordered)

Gimballed 2-burner stainless steel with oven with stainless steel protection bar (not compatible with microwave option)

Luxury 2-burner stove with black finish, wood handle, stainless steel oven/broiler

HEAD ROOM

Forward cabin

1,86 m

Aft cabin

1,89 m

Companioway

1,88 m

Saloon

1,85 m

Galley

1,89 m

■ Standard □ Option - Not available C = Cabins H = Head



JEANNEAU

